



PARS SHIR Mfg. Co.
Technology & safety

Model

Space heater valve - Type A

Brass gas taps with safety device

Construction

Body: Forged brass

Cone: Brass

Cap: Die cast aluminum alloy

Spindle: Brass

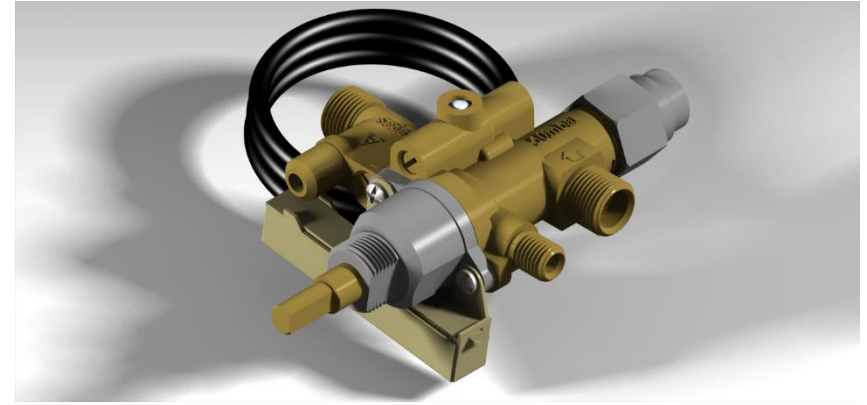

Connections

Standard Inlet: M12×1 male

Standard Outlet: M12×1 male

Spindle dimension: 5.5×6.35mm.

Shape according to customer's request

Functional data

Maximum working temperature: 100°C

Maximum working pressure: 65 mbar

Flow: 560 l/h

Internal leak tightness: < 20 cc/h (at 150 mbar)

Brass

Installation

Maximum inlet torque: 14 Nm.

Maximum outlet torque: 14 Nm.

Maximum thermocouple torque for different thread size: 4 Nm.

Spindle rotation diagram

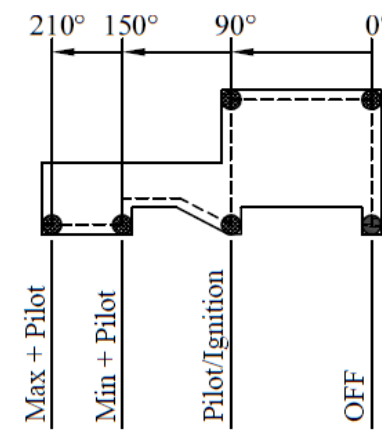

Overall dimensions

Operating Sequence

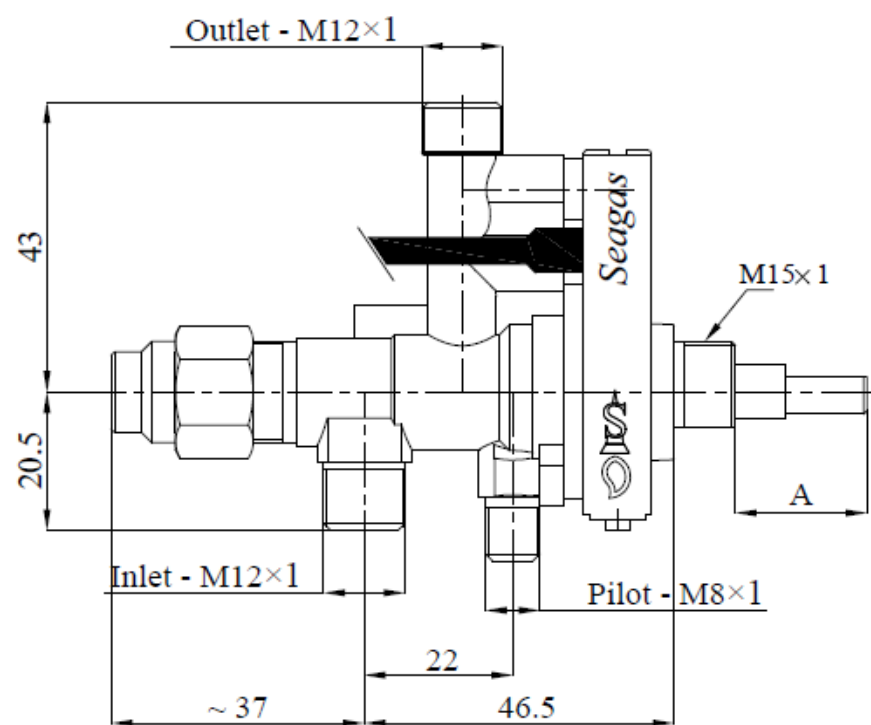

A: according to customer's request .

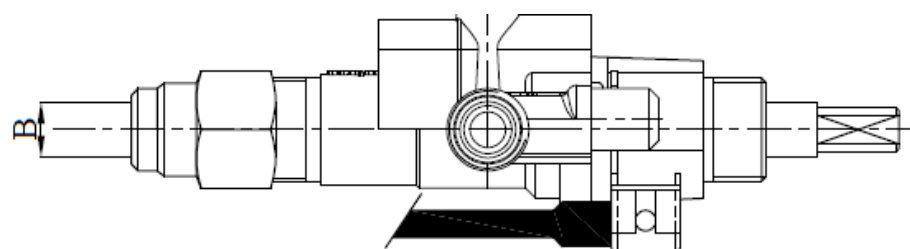

B: according to customer's request .

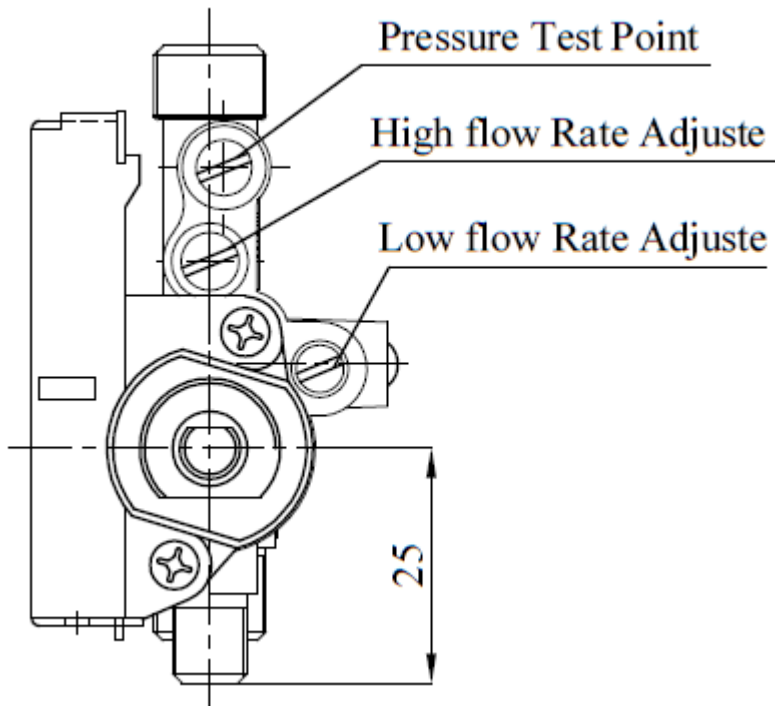

Magnet nuts according to customer's request

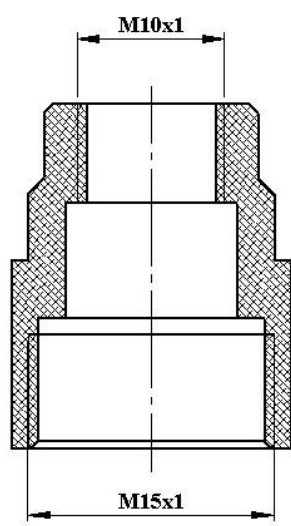

1

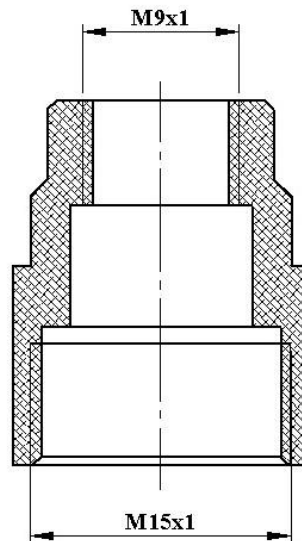

2

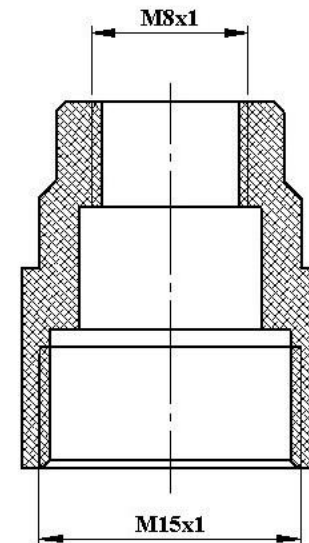

3

Magnet nut		
1	Type 1	M10x1
2	Type 2	M9x1
3	Type 3	M8x1